

C2-12	171.50.200	P20-14	171.43.000	PP20-1	171.47.000	AN 150	161.21.000
C1-12	171.50.050	P20-15	171.44.000	T3-150	161.32.000	BNI 45-150	161.20.500
P23-11	171.40.000	P20-16	171.45.000	T6-150	161.31.000	BNI 6-150	161.20.000
P23-12	171.41.000	P20-17	171.46.000	TD6-150	161.31.700	ABH 100	201.23.000
P20-13	171.42.000	P20-18	171.46.500	T12-150	161.31.500		

(H<sub>SR</sub>) ESTACIONARIA 1 / STATIONARY 1 / STATIONAIRE / СТАЦИОНАРНОЕ СОСТОЯНИЕ / SABIT / ثابتة

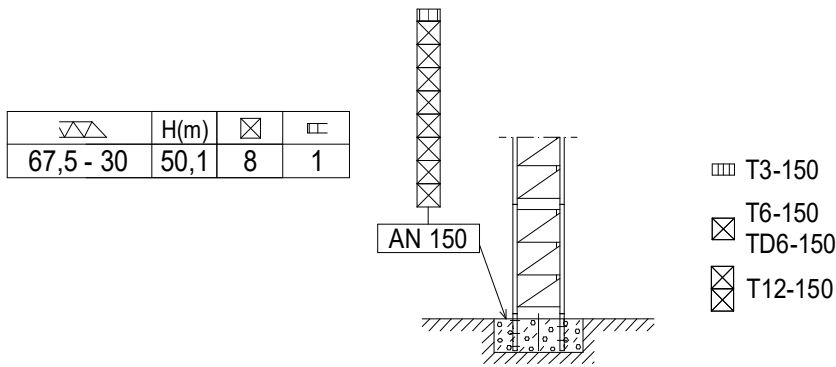

(H<sub>SR</sub>) ESTACIONARIA 3 / STATIONARY 3 / STATIONAIRE / СТАЦИОНАРНОЕ СОСТОЯНИЕ / SABIT / ثابتة

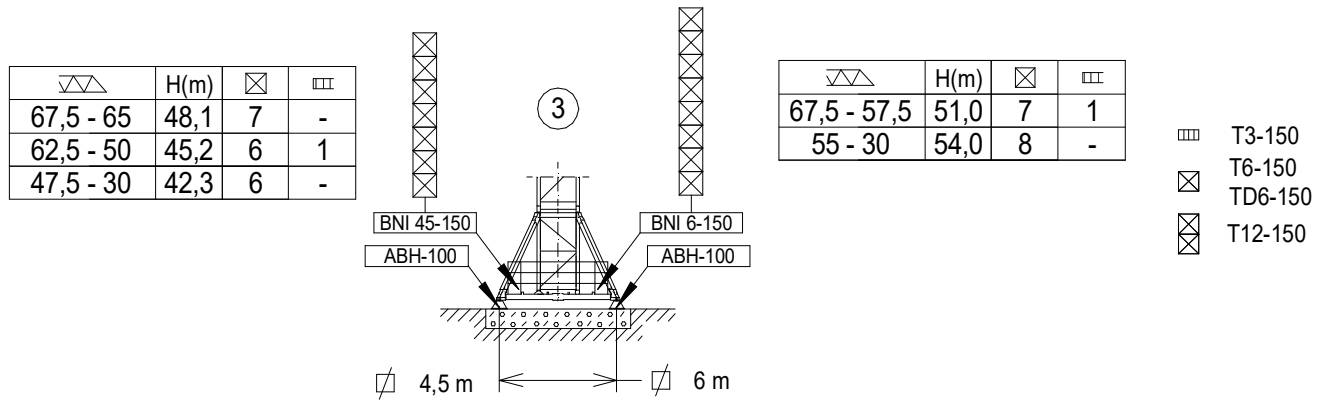

(H<sub>SR</sub>) TRASLACIÓN / TRAVELLING / TRASLATION / ПЕРЕМЕЩЕНИЕ / RAY YÜRÜYÜŞLÜ / متحركة

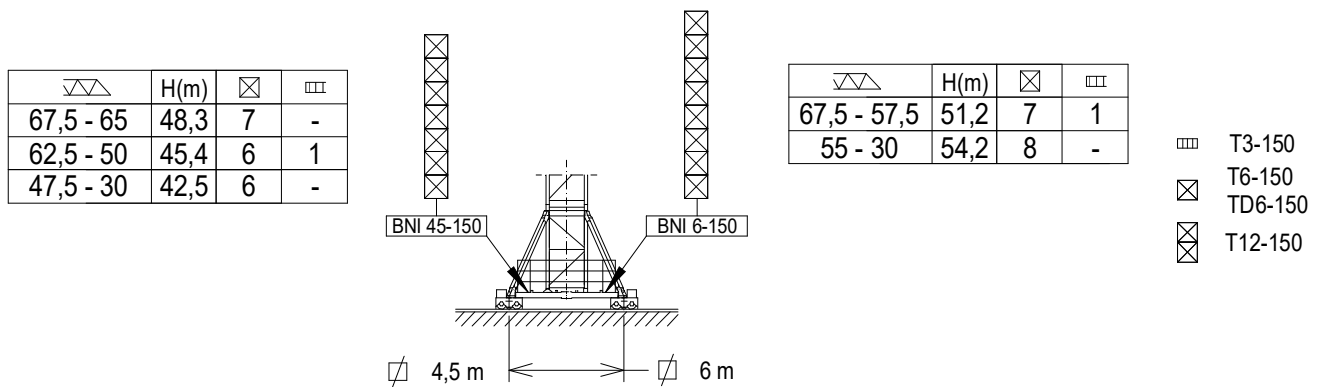

H= *Altura máxima bajo gancho sin arriostrar (m).*  
*Maximum height under hook without fastening (m).*  
*Hauteur maximale sous crochet sans ancrage (m).*  
*Максимальная высота под крюком без крепления (m).*  
*Bağlantısız maksimum kanca alti yüksekliği (m).*  
*أقصى ارتفاع تحت الخطاف بدون ربط (m)*

$H_{ST-DR} = H_{SR} - 0,3$   
 $H_{ST-SR} = H_{ST-DR}$

SR (t)		Cargas máximas / Maximum loads / Charges maximales / Максимальные нагрузки / Maksimum yük / أقصى حمولة SR – 6 t																			
[m]	6 t @ ... (m)	Alcance del gancho [m] / Hook reach [m] / Portée du crochet (m) / Радиус действия крюка (m) / Kancanın yüksekliği (m) / مدى الخطاف																			
		10	15	20	25	30	32,5	35	37,5	40	42,5	45	47,5	50	52,5	55	57,5	60	62,5	65	67,5
67,5	24,2	6,0	6,0	6,0	5,8	4,7	4,3	4,0	3,7	3,4	3,2	3,0	2,8	2,6	2,5	2,3	2,2	2,1	2,0	1,9	1,8
65,0	26,3	6,0	6,0	6,0	6,0	5,2	4,8	4,4	4,0	3,8	3,5	3,3	3,1	2,9	2,7	2,6	2,4	2,3	2,2	2,1	—
62,5	27,2	6,0	6,0	6,0	6,0	5,4	4,9	4,5	4,2	3,9	3,6	3,4	3,2	3,0	2,8	2,7	2,5	2,4	2,3	—	—
60,0	27,9	6,0	6,0	6,0	6,0	5,6	5,1	4,7	4,3	4,0	3,8	3,5	3,3	3,1	2,9	2,8	2,6	2,5	—	—	—
57,5	28,5	6,0	6,0	6,0	6,0	5,7	5,2	4,8	4,4	4,1	3,8	3,6	3,4	3,2	3,0	2,8	2,7	—	—	—	—
55,0	29,8	6,0	6,0	6,0	6,0	6,0	5,5	5,0	4,7	4,3	4,0	3,8	3,6	3,4	3,2	3,0	—	—	—	—	—
52,5	30,9	6,0	6,0	6,0	6,0	6,0	5,7	5,2	4,8	4,5	4,2	3,9	3,7	3,5	3,3	—	—	—	—	—	—
50,0	31,7	6,0	6,0	6,0	6,0	6,0	5,8	5,4	5,0	4,6	4,3	4,1	3,8	3,6	—	—	—	—	—	—	—
47,5	32,3	6,0	6,0	6,0	6,0	6,0	5,9	5,5	5,1	4,7	4,4	4,1	3,9	—	—	—	—	—	—	—	—
45,0	32,6	6,0	6,0	6,0	6,0	6,0	6,0	5,6	5,2	4,8	4,5	4,2	—	—	—	—	—	—	—	—	—
42,5	34,1	6,0	6,0	6,0	6,0	6,0	6,0	5,8	5,4	5,0	4,7	—	—	—	—	—	—	—	—	—	—
40,0	35,1	6,0	6,0	6,0	6,0	6,0	6,0	6,0	5,6	5,2	—	—	—	—	—	—	—	—	—	—	—
37,5	35,2	6,0	6,0	6,0	6,0	6,0	6,0	6,0	5,6	—	—	—	—	—	—	—	—	—	—	—	—
35,0	35,0	6,0	6,0	6,0	6,0	6,0	6,0	6,0	—	—	—	—	—	—	—	—	—	—	—	—	—
32,5	32,5	6,0	6,0	6,0	6,0	6,0	6,0	—	—	—	—	—	—	—	—	—	—	—	—	—	—
30,0	30,0	6,0	6,0	6,0	6,0	6,0	—	—	—	—	—	—	—	—	—	—	—	—	—	—	—

Fecha / Date: 06/07/2021

 FEM 1005 - C25

Reservado el derecho a modificaciones sin previo aviso. Declinamos toda responsabilidad derivada de la información proporcionada / Subject to modification, without prior notice. This information is supplied without liability / L'entreprise se réserve le droit de procéder à des modifications sans préavis. Nous déclinons toute responsabilité quant aux informations fournies / Мы оставляем за собой право на внесение изменений без предварительного уведомления. Мы снимаем с себя любую ответственность в отношении предоставленной информации / Onceden bildirilmeksizin değiştirilme hakkı saklıdır. Verilen bilgiler için hiçbir sorumluluk kabul etmemekteyiz / حقوق التغيير محفوظة دون إشعار مسبق. دون أدنى مسؤولية عن المعلومات المقدمة

CARGAS / LOADS / CHARGES / НАГРУЗКИ / YÜKLER / الأحمال																				J200.12	
ST-SR (t)		Cargas máximas / Maximum loads / Charges maximales / Максимальные нагрузки / Maksimum yük / أقصى حمولة																			
ST-SR - 6 t																					
[m]	6 t @ ... (m)	Alcance del gancho [m] / Hook reach [m] / Portée du crochet (m) / Радиус действия крюка (m) / Kancanın yüksekliği (m) / مدى الخطاف																			
		10	15	20	25	30	32,5	35	37,5	40	42,5	45	47,5	50	52,5	55	57,5	60	62,5	65	67,5
67,5	23,8	6,0	6,0	6,0	5,7	4,6	4,2	3,9	3,6	3,3	3,1	2,9	2,7	2,5	2,4	2,2	2,1	2,0	1,9	1,8	1,7
65,0	25,9	6,0	6,0	6,0	6,0	5,1	4,6	4,3	3,9	3,7	3,4	3,2	3,0	2,8	2,6	2,5	2,3	2,2	2,1	2,0	—
62,5	26,8	6,0	6,0	6,0	6,0	5,3	4,8	4,4	4,1	3,8	3,5	3,3	3,1	2,9	2,7	2,6	2,4	2,3	2,2	—	—
60,0	27,5	6,0	6,0	6,0	6,0	5,4	5,0	4,6	4,2	3,9	3,6	3,4	3,2	3,0	2,8	2,7	2,5	2,4	—	—	—
57,5	28,1	6,0	6,0	6,0	6,0	5,6	5,1	4,7	4,3	4,0	3,7	3,5	3,3	3,1	2,9	2,7	2,6	—	—	—	—
55,0	29,3	6,0	6,0	6,0	6,0	5,9	5,4	4,9	4,6	4,2	3,9	3,7	3,5	3,3	3,1	2,9	—	—	—	—	—
52,5	30,4	6,0	6,0	6,0	6,0	6,0	5,6	5,1	4,7	4,4	4,1	3,8	3,6	3,4	3,2	—	—	—	—	—	—
50,0	31,2	6,0	6,0	6,0	6,0	6,0	5,7	5,3	4,9	4,5	4,2	3,9	3,7	3,5	—	—	—	—	—	—	—
47,5	31,8	6,0	6,0	6,0	6,0	6,0	5,8	5,4	5,0	4,6	4,3	4,0	3,8	—	—	—	—	—	—	—	—
45,0	32,1	6,0	6,0	6,0	6,0	6,0	5,9	5,5	5,0	4,7	4,4	4,1	—	—	—	—	—	—	—	—	—
42,5	33,5	6,0	6,0	6,0	6,0	6,0	6,0	5,7	5,3	4,9	4,6	—	—	—	—	—	—	—	—	—	—
40,0	34,6	6,0	6,0	6,0	6,0	6,0	6,0	5,9	5,5	5,1	—	—	—	—	—	—	—	—	—	—	—
37,5	34,7	6,0	6,0	6,0	6,0	6,0	6,0	5,9	5,5	—	—	—	—	—	—	—	—	—	—	—	—
35,0	35,0	6,0	6,0	6,0	6,0	6,0	6,0	6,0	—	—	—	—	—	—	—	—	—	—	—	—	—
32,5	32,5	6,0	6,0	6,0	6,0	6,0	6,0	—	—	—	—	—	—	—	—	—	—	—	—	—	—
30,0	30,0	6,0	6,0	6,0	6,0	6,0	—	—	—	—	—	—	—	—	—	—	—	—	—	—	—

CARGAS / LOADS / CHARGES / НАГРУЗКИ / YÜKLER / الأحمال																				J200.12	
ST-DR (t)		Cargas máximas / Maximum loads / Charges maximales / Максимальные нагрузки / Maksimum yük / أقصى حمولة																			
ST-DR - 12 t																					
[m]	12 t @ ... (m)	Alcance del gancho [m] / Hook reach [m] / Portée du crochet (m) / Радиус действия крюка (m) / Kancanın yüksekliği (m) / مدى الخطاف																			
		10	15	20	25	30	32,5	35	37,5	40	42,5	45	47,5	50	52,5	55	57,5	60	62,5	65	67,5
67,5	12,6	12,0	9,9	7,2	5,6	4,5	4,1	3,7	3,4	3,2	2,9	2,7	2,5	2,3	2,2	2,0	1,9	1,8	1,7	1,6	1,5
65,0	13,6	12,0	10,8	7,9	6,1	5,0	4,5	4,1	3,8	3,5	3,2	3,0	2,8	2,6	2,4	2,3	2,2	2,2	1,9	1,8	—
62,5	14,1	12,0	11,2	8,2	6,4	5,1	4,7	4,3	3,9	3,6	3,4	3,1	2,9	2,7	2,6	2,4	2,3	2,1	2,0	—	—
60,0	14,4	12,0	11,5	8,4	6,5	5,3	4,8	4,4	4,1	3,7	3,5	3,2	3,0	2,8	2,6	2,5	2,3	2,2	—	—	—
57,5	14,7	12,0	11,8	8,6	6,7	5,4	4,9	4,5	4,2	3,8	3,6	3,3	3,1	2,9	2,7	2,6	2,4	—	—	—	—
55,0	15,3	12,0	12,0	9,0	7,0	5,7	5,2	4,8	4,4	4,1	3,8	3,5	3,3	3,0	2,9	2,7	—	—	—	—	—
52,5	15,9	12,0	12,0	9,3	7,3	5,9	5,4	5,0	4,6	4,2	3,9	3,6	3,4	3,2	3,0	—	—	—	—	—	—
50,0	16,3	12,0	12,0	9,6	7,5	6,1	5,6	5,1	4,7	4,3	4,0	3,8	3,5	3,3	—	—	—	—	—	—	—
47,5	16,6	12,0	12,0	9,8	7,6	6,2	5,7	5,2	4,8	4,4	4,1	3,9	3,6	—	—	—	—	—	—	—	—
45,0	16,7	12,0	12,0	9,9	7,7	6,3	5,7	5,3	4,9	4,5	4,2	3,9	—	—	—	—	—	—	—	—	—
42,5	17,5	12,0	12,0	10,4	8,1	6,6	6,0	5,5	5,1	4,7	4,4	—	—	—	—	—	—	—	—	—	—
40,0	18,0	12,0	12,0	10,7	8,4	6,8	6,2	5,7	5,3	4,9	—	—	—	—	—	—	—	—	—	—	—
37,5	18,0	12,0	12,0	10,7	8,5	6,8	6,3	5,7	5,3	—	—	—	—	—	—	—	—	—	—	—	—
35,0	18,2	12,0	12,0	10,8	8,5	6,9	6,3	5,8	—	—	—	—	—	—	—	—	—	—	—	—	—
32,5	18,1	12,0	12,0	10,8	8,5	6,9	6,3	—	—	—	—	—	—	—	—	—	—	—	—	—	—
30,0	18,1	12,0	12,0	10,8	8,5	6,9	—	—	—	—	—	—	—	—	—	—	—	—	—	—	—









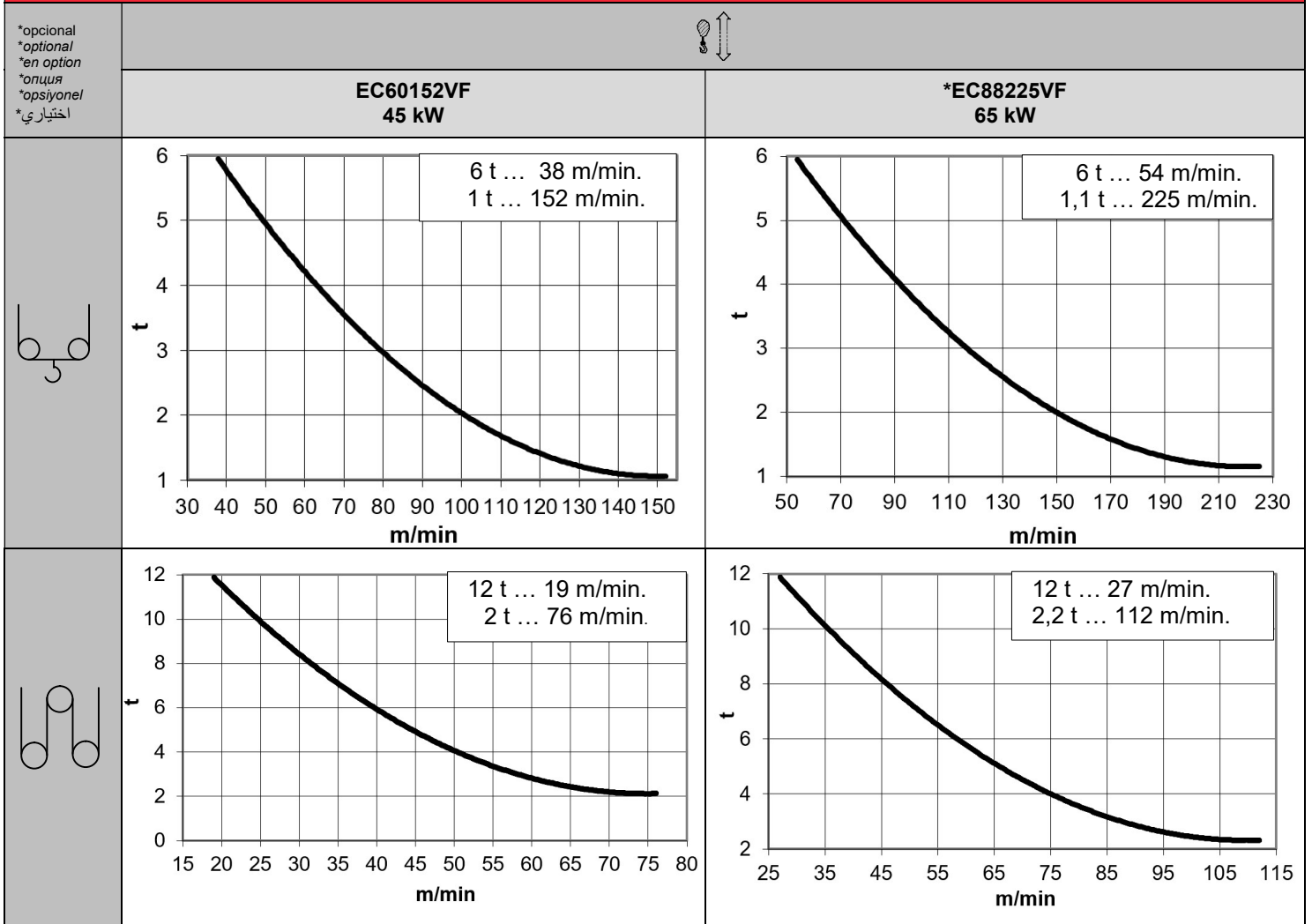

Fecha / Date: 06/07/2021

FEM 1005 - C25

Reservado el derecho a modificaciones sin previo aviso. Declinamos toda responsabilidad derivada de la información proporcionada / Subject to modification, without prior notice. This information is supplied without liability / L'entreprise se réserve le droit de procéder à des modifications sans préavis. Nous déclinons toute responsabilité quant aux informations fournies / Мы оставляем за собой право на внесение изменений без предварительного уведомления. Мы снимаем с себя любую ответственность в отношении предоставленной информации / Onceden bildirilmeksizin değiştirilme hakkı saklıdır. Verilen bilgiler için hiçbir sorumluluk kabul etmemekteyiz / حقوق التغيير محفوظة دون إشعار مسبق. دون أدنى مسؤولية عن المعلومات المقدمة

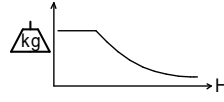
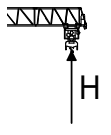





				 <b>400V 50Hz</b>	 
<b>TG2020VF</b> 2x7,3 kW	<b>OG2208VF</b> 3 x 5,5 kW	<b>TC770VF</b> 5,5 kW	<b>TH1506</b> 11 kW	<b>P<sub>TOTAL</sub> (EC60152VF + OG2208VF + TC770VF) = 67 kW</b> <b>P<sub>TOTAL</sub> (EC88225VF+ OG2208VF + TC770VF) = 87 kW</b>	
0...20 m/min	0...0,8 r/min sl/min	6 t 0...70 m/min  12 t 0...35 m/min	1 m/min	 <b>H ≤ SR 534 m</b> <b>DR 267 m</b>   <b>1378 m</b>	

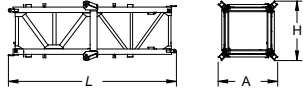
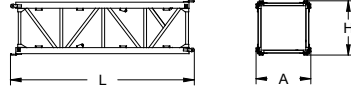
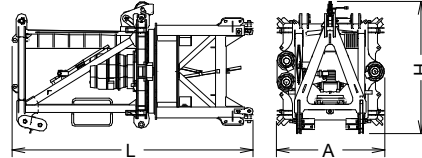
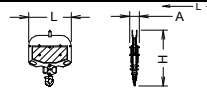

Fecha / Date: 06/07/2021

 **FEM 1005 - C25**

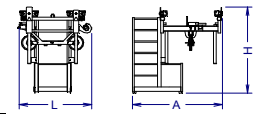
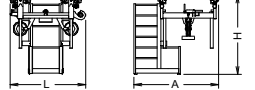
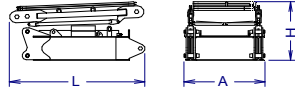
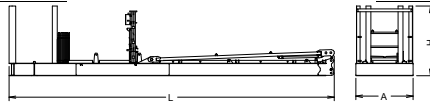
Reservado el derecho a modificaciones sin previo aviso. Declinamos toda responsabilidad derivada de la información proporcionada / Subject to modification, without prior notice. This information is supplied without liability / L'entreprise se réserve le droit de procéder à des modifications sans préavis. Nous déclinons toute responsabilité quant aux informations fournies / Мы оставляем за собой право на внесение изменений без предварительного уведомления. Мы снимаем с себя любую ответственность в отношении предоставленной информации / Onceden bildirilmeksizin değiştirilme hakkı saklıdır. Verilen bilgiler için hiçbir sorumluluk kabul etmemekteyiz / حقوق التغيير محفوظة دون إشعار مسبق. دون أدنى مسؤولية عن المعلومات المقدمة

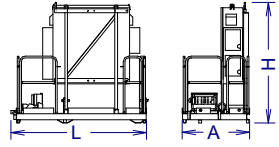
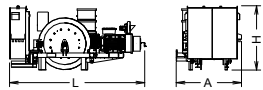
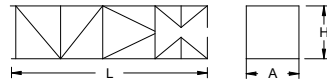
DENOMINACIÓN / DENOMINATION / DÉSIGNATION / НАЗВАНИЕ / AÇIKLAMA / اسم	L [m]	A [m]	H [m]	P / W [kg]
Torre inferior / Lower tower / Tour inférieure / Нижняя башня / Alt kule / البرج السفلي	TI-6-150			6,175 2,190 2,190 3535
Torre / Tower	T6-150			6,175 1,870 1,870 2760
Torre / Tower	TD6-150			6,175 1,870 1,870 2930
Torre / Башня / Kule / برج	TT6-150			6,175 1,870 1,870 2760
	T3-150			3,265 1,870 1,870 1550
	T12-150			12,000 1,870 1,870 5180
Torre asiento pista + punta de torre + orientación Slewing table + tower head + slewing mechanism Tour pivot + porte-flèche + mécanisme d'orientation Сиденье площадки + верхней секции башни + поворотный механизм Göbek +kule kafa bölümü +mekanizma برج وحدة الدوارن + رأس البرج + آلية الدوران				4,630 2,080 2,490 6900
Tramo de pluma	P23-11			10,280 1,356 2,495 2575
Jib section	P23-12+tr			10,280 1,126 2,475 2570
Tronçon de flèche	P20-13			10,235 1,126 2,215 1620
Секция стрелы	P20-14			10,190 1,126 2,195 1195
Вот bölümü	P20-15			10,190 1,126 2,155 815
أجزاء الذراع	P20-16			10,190 1,126 2,215 570
	P20-17			5,180 1,126 2,215 350
	P20-18			2,680 1,126 2,190 190
	PP20-1			0,890 1,290 2,500 130
Polipasto / Hook assembly Palan / Полиспаст Kanca takımı / بكرة	SR – 6 t			0,860 0,200 1,126 220
	ST-DR – 12 t			1,410 0,545 1,494 480
Carro / Trolley Chariot / Грузовая тележка Şaryo / عربة	SR – 6 t			1,560 1,935 1,891 320
	ST-DR – 12 t			1,753 1,962 1,860 420
Contrapluma / Counterjib / Contre-flèche Противовесная консоль Kuuyruk / الذراع المعاكس	C1-12			2,398 1,430 1,100 1080
Contrapluma / Counterjib / Contre-flèche Противовесная консоль Kuuyruk / الذراع المعاكس	C2-12			11,982 2,106 2,500 5535
Plataforma y cabina / Platform and cabin Plateforme et cabine / Платформа и кабина Platform ve kabin / منصة وكابينة				3,520 2,060 2,400 1.120
Armario eléctrico y plataforma Electrical cabinet and platform armoire électrique et plateforme				2,655 1,317 2,339 821
Soporte y elevación (sin cable) / Support and hoisting (without rope) / Support et levage (sans câble) Опора и подъем (без троса) / Destek ve vinç kulesi (kabloşuz) / دعم ورفع (بدون كابل)				3,800 1,840 1,840 3710
Estructura torre de montaje Jacking cage structure Structure de tour de montage Структура монтажной башни Kaldırma kafesi yapısı	TM6-150			10,320 2,420 2,310 3500

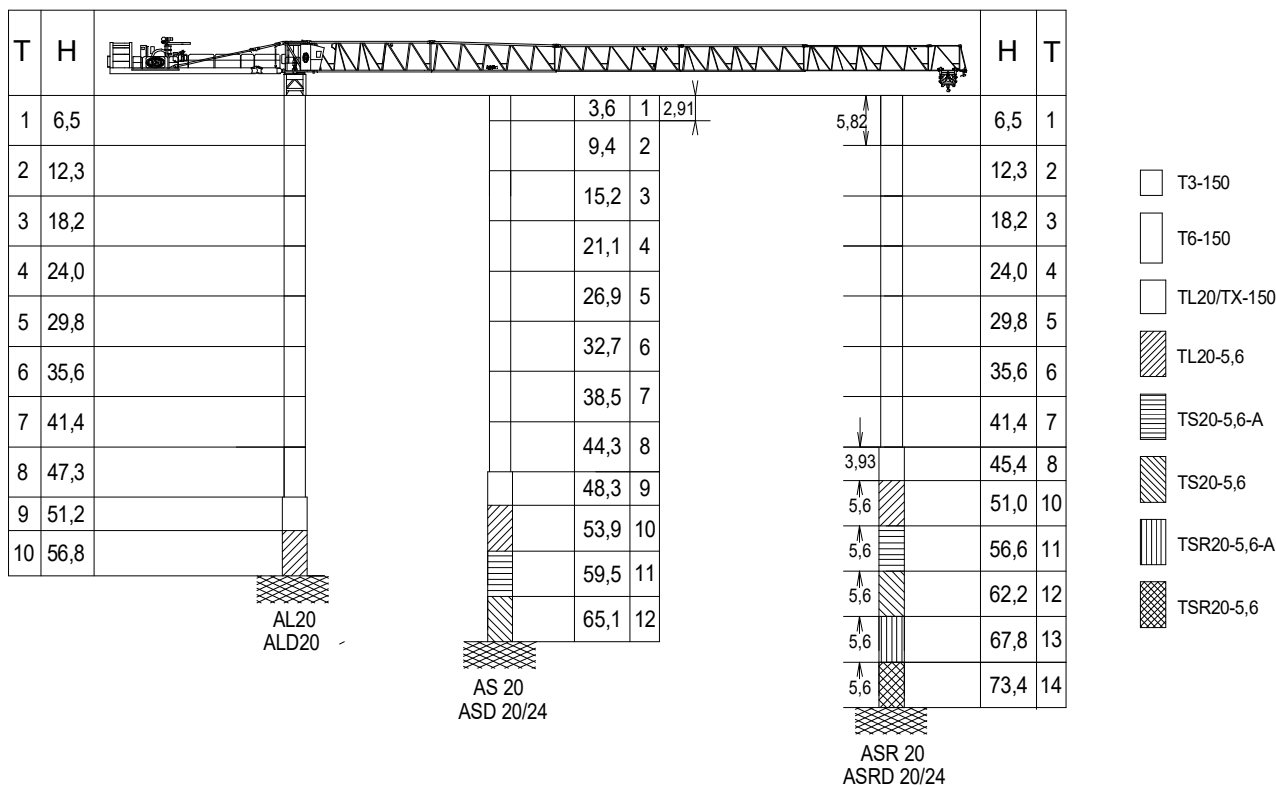

T: Torre / Tower / Tour / Башни / Kuleler / أبراج H: Altura / Height / Hauteur / Высота / Yükseklik / ارتفاع	$H_{ST-DR} = H_{SR} - 0,3$ $H_{ST-SR} = H_{ST-DR}$	TL20/TX-150----- 161.36.000 TL20-5,6----- 204.31.400 TS20-5,6A----- 204.31.500 TS20-5,6----- 204.31.200 TSR20-5,6A----- 204.31.300 TSR20-5,6----- 204.31.000	AL 20----- 153.21.800 ALD 20----- 160.21.250 AS 20----- 160.21.010 ASD 20/24----- 160.21.080 ASR 20----- 160.21.200 ASRD 20/24----- 156.21.000
---	---	---	---

**i** Otras configuraciones de torre / Other tower configuration / Autres configurations / Прочие конфигурации / Diğer konfigürasyonlar / مكونات أخرى

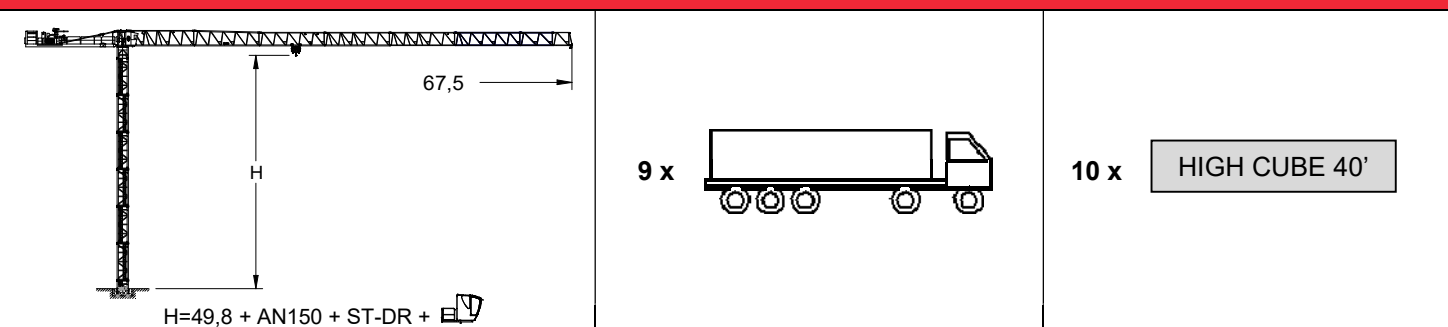

- f** Viento fuera de servicio / Out of service wind / Vitesse du vent hors service / Ветровая нагрузка в покое / Rüzgar devre dışı / الريح خارج الخدمة
- i** Consultar / Consult / Nous consulter / Консультируемся / Danışınız / الرجوع إلى
- ▶** En servicio / In service / En service / В работе / Devrede / في الخدمة
- Fuera de servicio / Out of service / Hors service / В покое / Devre dışı / خارج الخدمة



Ctra./Rd. Madrid - Irún Km. 415 - 20.213 IDIAZABAL [Gipuzkoa] ESPAÑA / SPAIN  
P.O. Box, 23 - 20.200 BEASAIN - E-mail: jaso@jaso.com  
Tel. +34 943 - 18 70 00 • Fax. +34 943 - 18 70 20  
**www.jaso.com**

Fecha / Date: 06/07/2021

**FEM 1005 - C25**

DELEGACION / DEALER

Reservado el derecho a modificaciones sin previo aviso. Declinamos toda responsabilidad derivada de la información proporcionada / Subject to modification, without prior notice. This information is supplied without liability / L'entreprise se réserve le droit de procéder à des modifications sans préavis. Nous déclinons toute responsabilité quant aux informations fournies / Мы оставляем за собой право на внесение изменений без предварительного уведомления. Мы снимаем с себя любую ответственность в отношении предоставленной информации / Önceden bildirilmeksizin değiştirilme hakkı saklıdır. Verilen bilgiler için hiçbir sorumluluk kabul etmemekteyiz / حقوق التغيير محفوظة دون إشعار مسبق. دون أدنى مسؤولية عن المعلومات المقدمة